

Type 190x

Thread mill with GCT MicroSpeed diamond coating

Applications / Advantages:

- Ideally suited for internal thread milling in glass, quartz, technical ceramics such as Al₂O₃, AlN, ZrO₂
- High dimensional accuracy and process capability due to **thicker diamond coating** and application-specific design



MicroSpeed diamond coating - Made by GCT in Germany

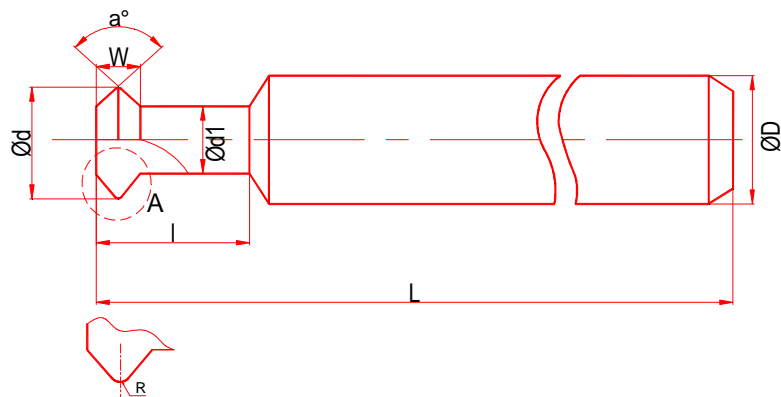

metric thread	Ø d	Ø d1	l	R	L	Ø D
M1.6 x 0.35 1903 1635 038 4	1.20	0.85	5.0	0.03	38.10	3.00
M2 x 0.4 1903 2040 038 4	1.53	1.00	6.0	0.03	38.10	3.00
M2.5 x 0.45 1903 2545 038 4	1.97	1.37	7.0	0.03	38.10	3.00
M3 x 0.5 1903 3050 038 4	2.41	1.75	8.0	0.04	38.10	3.00
M4 x 0.7 1903 4070 038 4	3.17	2.25	10.0	0.05	38.10	3.00
M5 x 0.8 1905 5080 038 9	4.04	3.00	15.0	0.06	38.10	5.00
M6 x 1.0 1905 6100 038 9	4.80	3.60	15.0	0.07	38.10	5.00
M8 x 1.25 1906 8125 050 9	6.00	3.96	20.0	0.09	50.00	6.00

Further versions on request.

Standard version:

- tolerances according to GCT specifications
- made of solid carbide

NEW