

Type 1940

Thread mill with GCT MicroSpeed diamond coating

Applications / Advantages:

- Ideally suited for inner thread in IMS, aluminium and copper
- High dimensional accuracy and process capability due to application-specific design



MicroSpeed diamond coating - Made by GCT in Germany

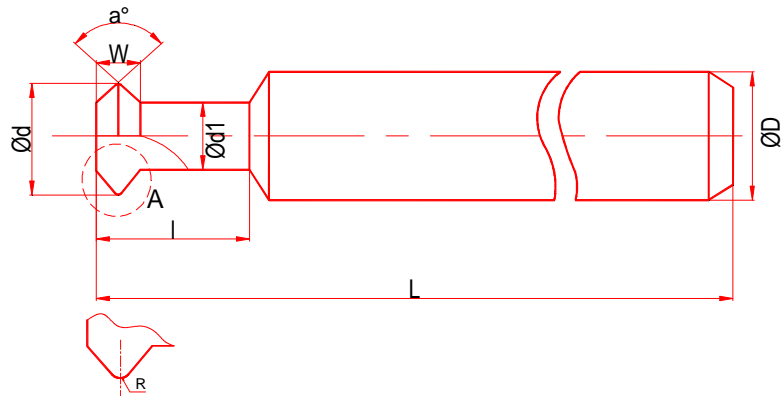

| metric thread | Ø d | Ø d1 | l | R |
|---------------------------------------|------|------|-----|-------|
| M2.5 x 0.45 1940 2545 038 4 | 1.97 | 1.25 | 5.0 | 0.025 |
| M3 x 0.5 1940 3050 038 4 | 2.41 | 1.50 | 6.0 | 0.030 |
| M4 x 0.7 1940 4070 038 4 | 3.17 | 2.00 | 6.0 | 0.040 |

Further versions on request.

Standard version:

- shank Ø 3.175mm
- overall length 38.10mm
- tolerances according to GCT router specification
- made of solid carbide

NEW